

Uninterruptible Power Supply

ON LINE UPS

1-10KVA

USER **MANUAL**

Contents

1. Introduction.....	1
2. Safety Instructions.....	2
3. Description of commonly used Notations.....	5
4. System Description	6
5. Connection and Operation	14
6. Trouble Shooting	21
7. Maintenance	23
8. Technical data	24
9. Communication Port	27
10. Appendix.....	28

1. Introduction

This On-Line-Series is an uninterruptible power supply incorporating double-converter technology. It provides perfect protection specifically for Novell, Windows NT and UNIX servers.

The double-converter principle eliminates all mains power disturbances. A rectifier converts the alternating current from the socket outlet to direct current. This direct current charges the batteries and powers the inverter. On the basis of this DC voltage, the inverter generates a sinusoidal AC voltage, which permanently supplies the loads. Computers and periphery are thus powered entirely by the mains voltage. In the event of power failure, the maintenance-free batteries power the inverter.

This manual covers the UPS listed as follows. Please confirm whether it is the model you intend to purchase by performing a visual inspection of the Model No. on the rear panel of the UPS.

Model	Type	Model	Type
1KVAS	Standard	1KVAH	Long backup time
1KVAR		1KVARH	
2KVAS		2KVAH	
2KVAR		2KVARH	
3KVAS		3KVAH	
3KVAR		3KVARH	
6KVAS		6KVAH	
6KVAR		6KVARH	
10KVAS		10KVAH	
/		3P10KVAH	

Remark:

- “S” Model: with inbuilt battery for short backup time
- “H” Model: with external battery for long backup time.
- “R” Model: Rack mount model
- “3P” Model: 3:1

2. Safety Instructions

PLEASE READ THE FOLLOWING USER MANUAL AND THE SAFETY INSTRUCTIONS BEFORE INSTALLING THE UNIT AND STARTING IT UP!

2-1 Transport

Please transport the UPS system only in the original packaging (to protect against shock and impact).

2-2 Set-up

- » Condensation may occur if the UPS system is moved directly from a cold to a warm environment. The UPS system must be absolutely dry before being installed. Please allow an acclimatization time of at least two hours.
- » Do not install the UPS system near water or in damp environments.
- » Do not install the UPS system where it would be exposed to direct sunlight or near heat.
- » Do not block off ventilation openings in the UPS system's housing.

2-3 Installation

- » Do not connect appliances or items of equipment which would overload the UPS system (e.g. laser printers) to the UPS outlet socket
- » Place cables in such a way that no one can step on or trip over them.
- » Do not connect domestic appliances such as hair dryers to UPS output sockets.
- » The UPS can be operated by any individuals with no previous experience

Installation for 1K / 2K / 3K

- » Connect the UPS system only to an earthed shockproof socket outlet.
 - » The building wiring socket outlet (shockproof socket outlet) must be easily accessible and close to the UPS system.
 - » This is operator installable
- When installing the equipment, it should ensure that the sum of the leakage current of the UPS and the connected consumer does not exceed 3.5mA.

Installation for 6K / 10K / 3P10K

- » Warning: This is a product for restricted sales distribution to informed partners.
- » Installation restrictions or additional measures may be needed to prevent disturbances.
- » A readily accessible disconnect device shall be incorporated in the building installation wiring and must be close to the UPS system.
- » This is permanently connected equipment and only qualified maintenance personnel may carry out installations.

2-4 Operation

- » Do not disconnect the mains cable on the UPS system or the building wiring socket outlet (shockproof socket outlet) during operations since this would cancel the protective earthing of the UPS system and of all connected loads.
- » The UPS system features its own, internal current source (batteries). The UPS output sockets or output terminals block may be electrically live even if the UPS system is not connected to the building wiring socket outlet.
- » In order to fully disconnect the UPS system, first press the Standby switch then disconnect the mains lead
- » Ensure that no fluids or other foreign objects can enter the UPS system.
- » The UPS operates with hazardous voltages. Only qualified maintenance personnel may carry out repairs













2-5 Maintenance, servicing and faults

- » The UPS system operates with hazardous voltages. Repairs Should be carried out only by qualified maintenance personnel.
- » Caution - risk of electric shock. Even after the unit is disconnected from the mains power supply (building wiring socket outlet), components inside the UPS system are still connected to the battery and are still electrically live and dangerous.
- » Before carrying out any kind of servicing and/or maintenance, disconnect the batteries and verify that no current is present and no hazardous voltage exist in the terminals of high capability capacitor such as BUS-capacitors.

- » For 6K / 10K / 3P10K models, the maintain switch, bypass switch and input switch are still electrically live and dangerous even after the input switch and bypass switch are disconnected on carrying out servicing and/or maintenance.
- » Only persons that are adequately familiar with batteries and with the required precautionary measures may replace batteries and supervise operations. Unauthorised persons must be kept well away from the batteries.
- » Caution - risk of electric shock. The battery circuit is not isolated from the input voltage. Hazardous voltages may occur between the battery terminals and the ground. Before touching, please verify that no voltage is present!
- » Batteries may cause electric shock and have a high short-circuit current. Please take the precautionary measures specified below and any other measures necessary when working with batteries:
 - remove wristwatches, rings and other metal objects
 - use only tools with insulated grips and handles.
- » When changing batteries, install the same number and same type of batteries.
- » Do not attempt to dispose of batteries by burning them. This could cause battery explosion.
- » Do not open or destroy batteries. Escaping electrolyte can cause injury to the skin and eyes. It may be toxic.
- » Please replace the fuse only by a fuse of the same type and of the same amperage in order to avoid fire hazards.
- » Do not dismantle the UPS system.

3. Description of commonly used notations

Some or all of the following Notations may be used in this manual and may appear in your application process. Therefore, all users should be familiar with them and understand their explanations.

Notation and Explanation	
Notation	Explanation
	Alert you to pay special attention
	Caution of high voltage
ON	Turn on the UPS
OFF	Turn off the UPS
	Idle or shut down the UPS
	Alternating current source(AC)
	Direct current source(DC)
	Protective ground
	Alarm silence
	Overload indication
	Battery check
	Recycle
	Display cycle button
	Battery

4. System Description

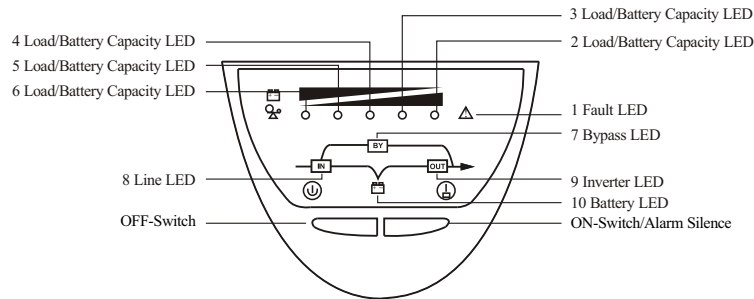

Figure 1: LED Display Panel 1

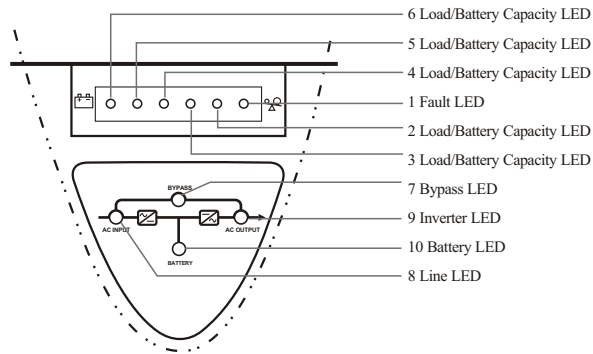

Figure 2: LED Display Panel 2

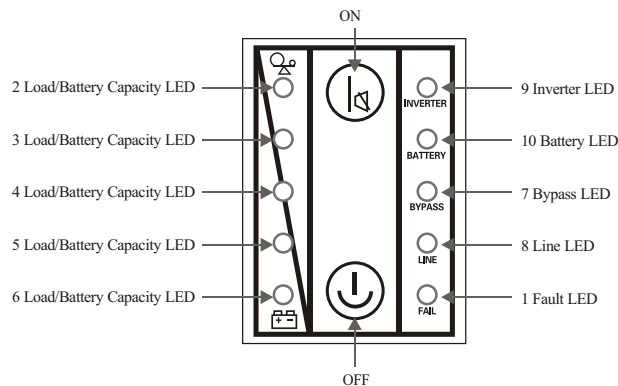

Figure 3: LEDR Display Panel

Switch	Function
ON - Switch	<ol style="list-style-type: none"> 1. Turn on UPS system: By pressing the ON-Switch “I” the UPS system is turned on. 2. Deactivate acoustic alarm: By pressing this switch an acoustic alarm can be deactivated.
OFF-Switch	<p>When mains power is normal, the UPS system switches to Standby mode by pressing OFF-Switch “⏻”. It is then switched to Bypass and the inverter is off.</p> <p>At this moment, the output sockets are supplied with voltage via the bypass if the mains power is available.</p>

Display	Function												
LINE LED	<ol style="list-style-type: none"> 1. The green LINE LED lights up if mains voltage is applied to the UPS input. 2. LINE LED blinks when the phase and neutral conductor have been reversed at the input of the UPS system. 3. If LINE LED and BATTERY-LED light up, the mains power supply is out of tolerance. 												
BATTERY LED	The orange-coloured BATTERY-LED lights up when the mains power has failed and the inverter is being powered by the batteries.												
BYPASS LED	The orange-coloured BYPASS LED lights up when the UPS system is supplying voltage provided by the mains power via the bypass.												
INVERTER LED	The green-coloured INVERTER LED lights up if the UPS system is supplying voltage provided by the mains power via the inverter.												
FAULT LED	The red FAULT LED lights up and an acoustic warning signal is issued continuously when the UPS system is in fault condition. Press the Standby switch in order to turn off the warning tone.												
LOAD/ BATTERY CAPACITY LEDs	<ol style="list-style-type: none"> 1. These LEDs show the load of the UPS system if the mains power is available (normal operation): <table border="0" style="margin-left: 20px;"> <tr> <td>2nd LED 96%-105 %</td> <td>3rd LED 76%-95 %</td> </tr> <tr> <td>4th LED 56%-75 %</td> <td>5th LED 36%-55 %</td> </tr> <tr> <td>6th LED 0-35 %</td> <td></td> </tr> </table> 2. In the battery operation, the LEDs indicate the capacity of the batteries: <table border="0" style="margin-left: 20px;"> <tr> <td>2nd LED 0-25 %</td> <td>3rd LED 26%-50 %</td> </tr> <tr> <td>4th LED 51%-75 %</td> <td>5th LED 76%-95 %</td> </tr> <tr> <td>6th LED 96%-100 %</td> <td></td> </tr> </table> 	2nd LED 96%-105 %	3rd LED 76%-95 %	4th LED 56%-75 %	5th LED 36%-55 %	6th LED 0-35 %		2nd LED 0-25 %	3rd LED 26%-50 %	4th LED 51%-75 %	5th LED 76%-95 %	6th LED 96%-100 %	
2nd LED 96%-105 %	3rd LED 76%-95 %												
4th LED 56%-75 %	5th LED 36%-55 %												
6th LED 0-35 %													
2nd LED 0-25 %	3rd LED 26%-50 %												
4th LED 51%-75 %	5th LED 76%-95 %												
6th LED 96%-100 %													

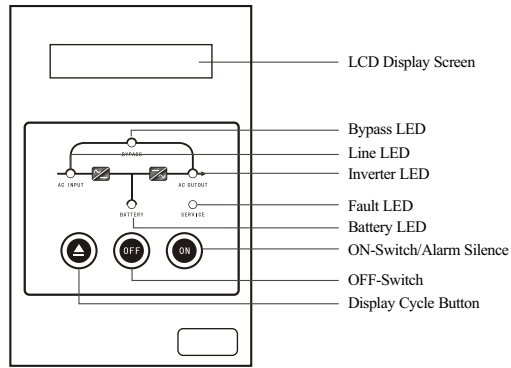

Figure 4: LCD Display Panel 1

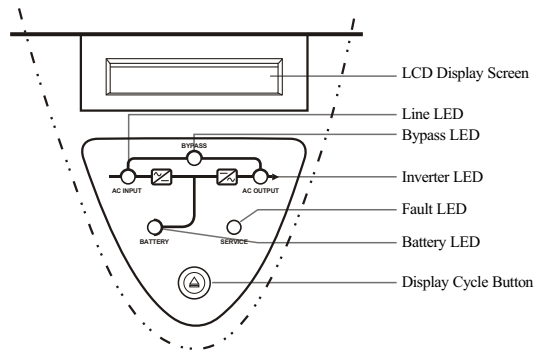

Figure 5: LCD Display Panel 2

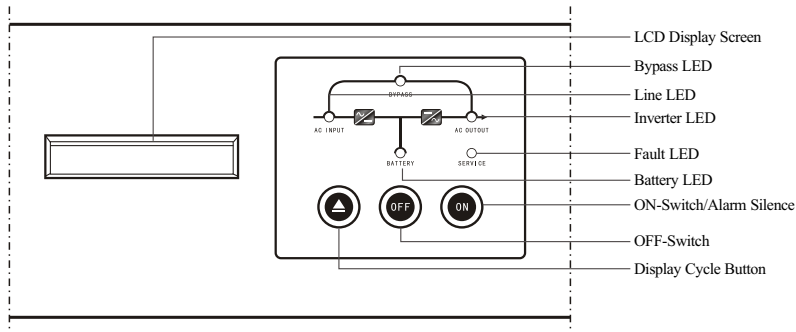

Figure 6: LCDR Display Panel

LCD display content and relative work model

» Main power in or first time UPS ON LCD display:



» UPS work at bypass model, press the “Display cycle button” on front panel, LCD will display as follows:

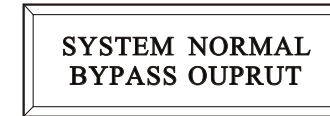

» UPS work at inverter model, press the “Display cycle button” on front panel, LCD will display as follows:

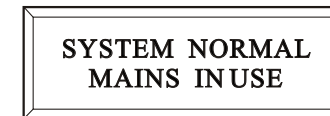

» Press the “Display cycle button” on front panel once more, LCD will display as follows:

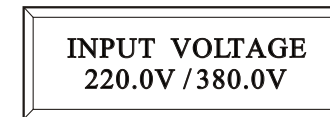

Here display the input main power voltage parameter, this numerical value can inspect main power voltage variety, from 0V~290V.

» Press the “Display cycle button” on front panel once more, LCD will display as follows:

INPUT FREQUENCY
50.0HZ

Here display the input main power frequency parameter, this numerical value can inspect main power frequency variety, from 0HZ~60HZ.

» Press the “Display cycle button” on front panel once more, LCD will display as follows:

OUTPUT VOLTAGE
220.0V

Here display the UPS output voltage parameter, this numerical value can inspect UPS output voltage variety, from 0V~290V.

» Press the “Display cycle button” on front panel once more, LCD will display as follows:

OUTPUT FREQUENCY
50.0HZ

Here display the UPS output frequency parameter, this numerical value can inspect UPS output frequency variety, from 0HZ~60HZ.

» Press the “Display cycle button” on front panel once more, LCD will display as follows:

BATTERY CAPACITY
100 %

Here display the UPS pile charge voltage or discharge voltage parameter, this numerical value can inspect UPS pile capacity variety, from 0%-100%.

» Press the “Display cycle button” on front panel once more, LCD will display as follows:

LOAD CAPACITY
100 %

Here display the UPS output load capacity parameter, this numerical value can inspect UPS take load capacity variety, from 0%~200%.

» If no main power, with main power but no bypass output, battery voltage low, overload, overheat, inside circuit fault, output short circuit etc, LCD will display relative content.

Like overload:

SYSTEM FAULT
BYPASS OUTPUT

And like no main power input:

SYSTEM NORMAL
BATTERY IN USE

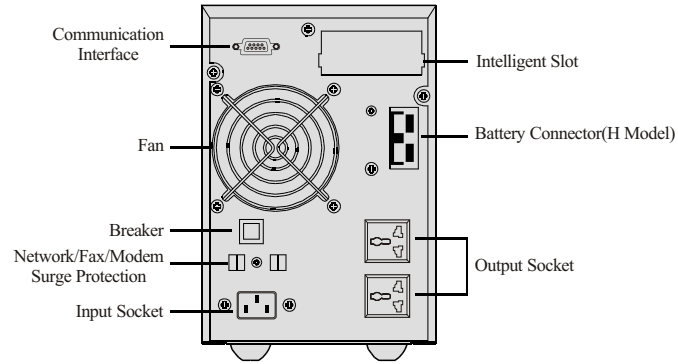

1KL Rear Panel

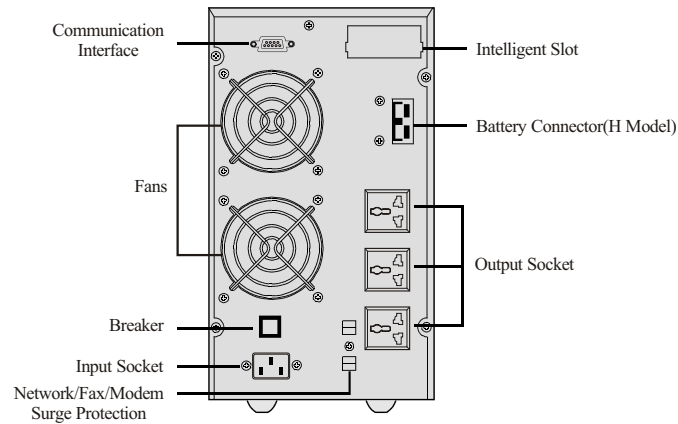

2KH / 3KH Rear Panel

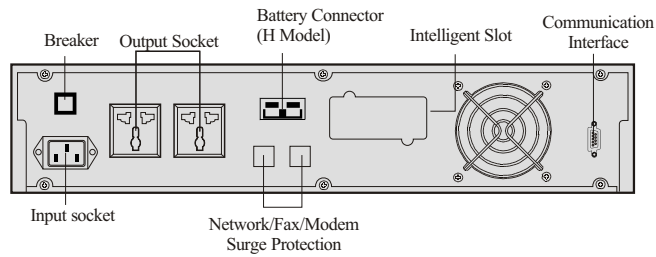

2KR / 3KR Rear Panel

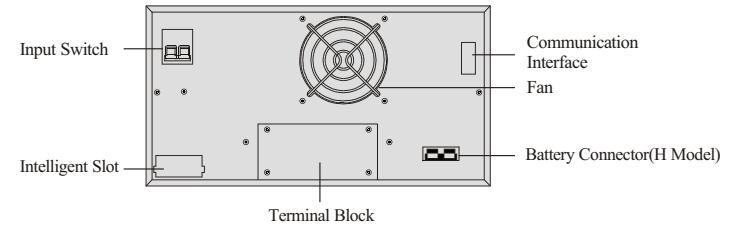

6KR Rear Panel

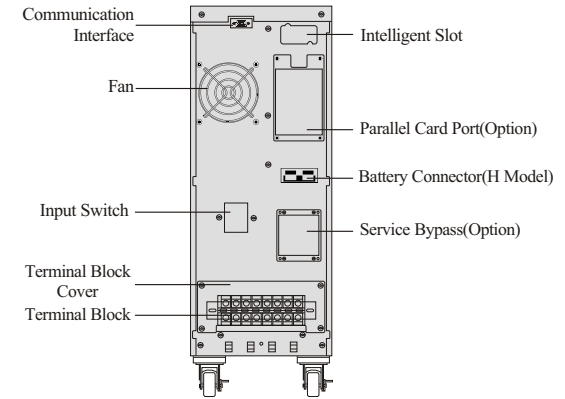

6K Rear Panel

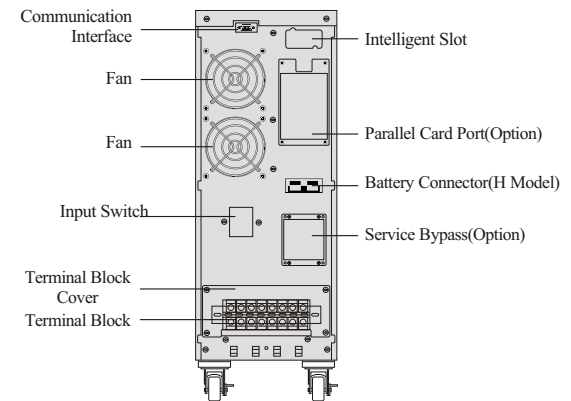

10K / 3P10K Rear Panel

5. Connection and Operation

THE SYSTEM MAY BE INSTALLED AND WIRED ONLY BY QUALIFIED ELECTRICIANS IN ACCORDANCE WITH APPLICABLE SAFETY REGULATIONS!

5.1 Connection and operation for 1K / 2K / 3K

WHEN INSTALLING THE ELECTRICAL WIRING, PLEASE NOTE THE NOMINAL AMPERAGE OF YOUR INCOMING FEEDER.

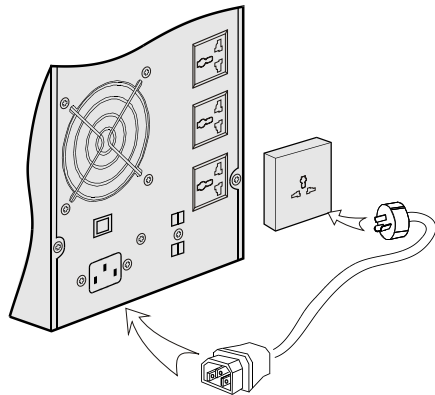

1/2/3KVA UPS Input connection

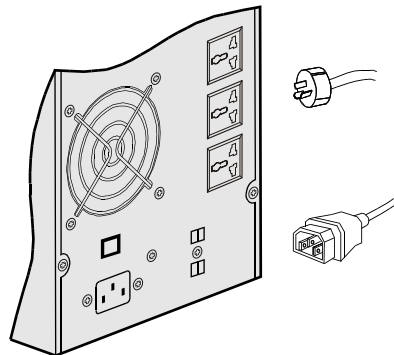

1/2/3KVA UPS Output Connection

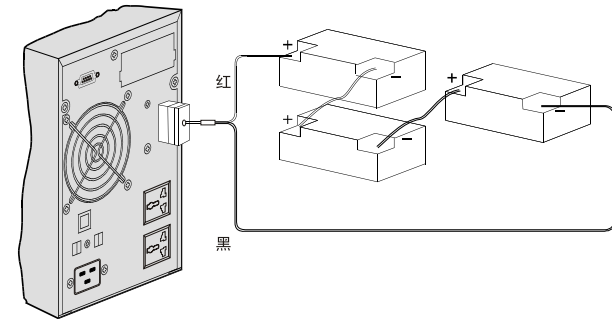

1KVAH External Battery Connection

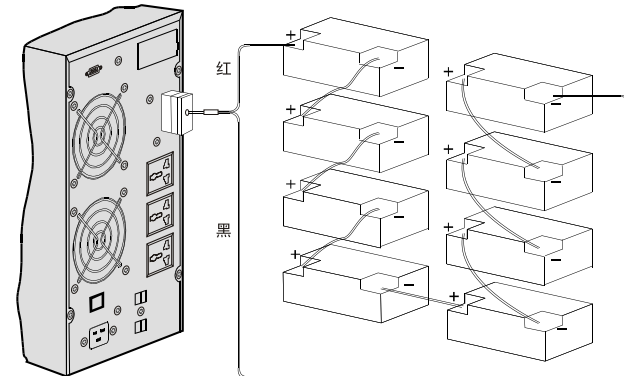

2/3KVAH External Battery Connection

1) **Inspection:**

Inspect the packaging carton and its contents for damage. Please inform the transport agency immediately should you find signs of damage.

Please keep the packaging in a safe place for future use.

Note: Please ensure that the incoming feeder is isolated and secured to prevent it from being switched back on again.

2) **Connection:**2-1) UPS Input Connection

If the UPS is connected via the power cord, please use a proper socket with protection against electric current, and pay attention to the capacity of the socket: over 10A for 1KS(H) & 2K, over 16A for 2KH & 3KS(H).

2-2) UPS Output Connection

The output of 1KS(H), 2KS(H) and 3KS(H) are socket-types only. Simply plug the load power cord to the output sockets to complete connection.

2-3) Computer Connection:

Connect your computer to the outlet sockets of the UPS system.

CAUTION!

DO NOT CONNECT EQUIPMENT WHICH WOULD OVERLOAD THE UPS SYSTEM (E. G. LASER PRINTERS).

3) Battery Charge: Fully charge the batteries of the UPS system by leaving the UPS system connected to the mains for 8-10 hours. You may use the UPS system directly without charging it but the stored energy time may be shorter than the nominal value specified.

4) Turn On the UPS:

4-1) With utility power connecting:

For 1K / 2K UPS, press “I” button continuously for more than 1 second to turn on the UPS. Then the UPS will get into self-test status first. After having finishing the self-test, the UPS will get into the inverter mode, at this time, the Utility Power LED, Inverter LED, and Load and Battery Capacity LEDs will light up.

4-2) Without utility power connecting:

Even though utility power is connected to the UPS, the UPS still can be turned on by just simply pressing “I” button continuously for more than 1 second. Then the UPS will get into self-test status first. After having finishing the self-test, the UPS will get into the inverter mode, at this time, Battery LED, Inverter LED, and Load and Battery Capacity LEDs will light up.

Note: The default setting for bypass mode is no output after UPS is connecting utility power and breaker is turned on. This can be configured by monitoring software.

5) Test Function:

Test the function of the UPS system by either pressing the On-Switch “I” or disconnecting the input of the UPS system from the power supply.

6) Turn Off the UPS:

6-1) In Inverter Mode: Press “ \cup ” button continuously for more than 1 second to turn off the UPS. Then the UPS will get into self-test status first. After having finished the self-test, the UPS will get into bypass mode and the Utility Power LED and Bypass LED will light up. At this time, the UPS might has output. Disconnect the utility power to turn off the output.

6-2) In Battery Mode: Press “ \cup ” button continuously for more than 1 second to turn off the UPS. Then the UPS will get into self-test status first. After having finished the self-test, the UPS will be turned off completely.

7) Audible Alarm Mute Function: If the alarm is too annoying in battery mode, you may press “I” button continuously for more than 1 second to clear it.

8) Operation Procedure of External Battery for Long Backup time Model
(“H” Model)

(1) Use the battery pack with voltage: 36Vdc for 1 KH (3 pcs of 12V batteries), 96Vdc for 2KH / 3KH (8 pcs of 12V batteries). Connection of batteries more than or less than required will cause abnormality.

(2) One end of the external battery cord is a plug for connecting the UPS and the other end has 3 (or 2) open wires for connecting the battery pack. The battery connection procedure is very important. Any incomppliance may result in the risk of electric shock. Therefore, the following steps must be strictly complied with.

(3) First connect in series the batteries of the pack to ensure proper battery voltage.

(4) Connect the external battery cord to the battery terminal (DO NOT connect the battery socket of the UPS first. Otherwise, it may cause electric shock). Connect the red wire to the "+" terminal of the battery. The black wire is connected to the "-" terminal of the battery. (Note: the green/yellow wire is grounded for protection purpose.)

(5) Do not connect the UPS to any load yet. Then, connect the power cord of the UPS to supply utility power to the UPS to make the UPS operation in utility power mode.

(6) Plug the external battery cord to the external battery socket on the rear panel of the UPS to complete the connection procedure and the UPS will start to charge the battery pack.

CAUTION!

THE OUTPUT SOCKETS OF THE UPS SYSTEM MAY STILL BE ELECTRICALLY LIVE EVEN IF THE POWER SUPPLY SYSTEM HAS BEEN DISCONNECTED OR THE BYPASS SWITCH IS ON "OFF" POSITION.

5.2 Connection and operation for 6K / 10K / 3P10K

WHEN INSTALLING THE ELECTRICAL WIRING, PLEASE NOTE THE NOMINAL AMPERAGE OF YOUR INCOMING FEEDER. THIS SERIES IS NOT SUITABLE FOR 16 A SUB-DISTRIBUTION BOARDS!

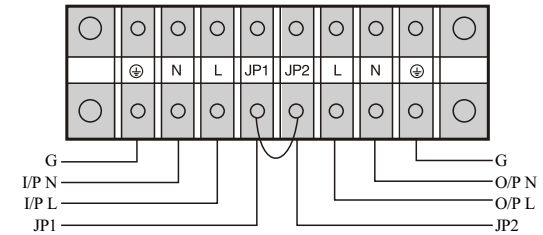

Connection diagram of 6K / 10K

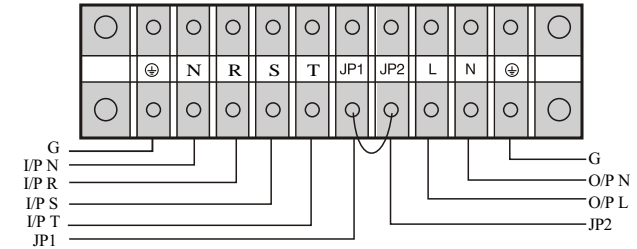

Connection diagram of 3P10K

1) Inspection: Inspect the packaging carton and its contents for damage. Please inform the transport agency immediately when you find signs of damage.

Please keep the packaging in a safe place for future use. Please ensure that the incoming feeder is isolated and secured to prevent it from being switched back on again. Set the Input switch on the back panel to position "OFF" .

2) Connection: Connect the UPS system to the mains at the screw terminals as shown in the diagram below:

3) Computer Connection: Connect your computer to the screw-type terminals of the UPS system as shown in the above diagram.

CAUTION!

DO NOT CONNECT EQUIPMENT WHICH WOULD OVERLOAD THE UPS SYSTEM (E.G. LASER PRINTERS).

4) UPS Setting: Set the Input switch on the back panel to "ON" position.

Note:

Load capacity LEDs first light up simultaneously, then extinguish one after another. After a few second the INVER-LED lights up and the BYPASS-LED goes out.

5) **Battery Charge:** Fully charge the batteries of the UPS system by leaving the UPS system connected to the mains for 8-10 hours. You can also use the UPS system directly without charging it but the stored energy time may then be shorter than the nominal value specified.

6) **Turn On the UPS:**

6-1) With utility power connecting: Press “I” button continuously for more than 1 second and set the Breaker on the rear panel to the “ON” position to turn on the UPS. Then the UPS will get into self-test status first. After having finishing the self-test, the UPS will get into the inverter mode, at this time, the Utility Power LED, Inverter LED, and Load and Battery Capacity LEDs will light up.

6-2) Without utility power connecting: Even though utility power is connected to the UPS, the UPS still can be turned on by just simply pressing “I” button continuously for more than 1 second. Then the UPS will get into self-test status first. After having finishing the self-test, the UPS will get into the inverter mode, at this time, Battery LED, Inverter LED, and Load and Battery Capacity LEDs will light up.

7) **Test Function:** Test the function of the UPS system by either pressing the On-Switch “I” or disconnecting the input of the UPS system from the power supply.

CAUTION!

THE OUTPUT SOCKETS OF THE UPS SYSTEM MAY STILL BE ELECTRICALLY LIVE EVEN IF THE POWER SUPPLY SYSTEM HAS BEEN DISCONNECTED OR THE UPS IS ON “OFF” POSITION.

8) **Turn Off the UPS:**

8-1) In Inverter Mode: Press “⏻” button continuously for more than 1 second to turn off the UPS. Then the UPS will get into self-test status first. After having finished the

self-test, the UPS will get into bypass mode and the Utility Power LED and Bypass LED will light up. At this time, the UPS still has output.

Disconnect the utility power or set Breaker to “OFF” position to turn off the output.

8-2) **In Battery Mode:** Press “⏻” button continuously for more than 1 second to turn off the UPS. Then the UPS will get into self-test status first. After having finished the self-test, the UPS will be turned off completely.

9) **Audible Alarm Mute Function:** If the alarm is too annoying in battery mode, you may press “I” button continuously for more than 1 second to clear it.

10) **Operation Procedure of External Battery for Long Backup time Model (“H” Model)**

10-1) Use the battery bank with voltage: 240VDC for 6KH / 10KH / 3P10KH (20 pcs of 12V batteries), Connection of batteries more than or less than required will cause abnormality.

The connection of batteries for 6KH / 10KH / 3P10KH is the same as 1KH / 2KH / 3KH

6. Trouble Shooting

If the UPS system does not operate correctly, please attempt to solve the problem using the table below.

<i>Problem</i>	<i>Possible cause</i>	<i>Remedy</i>
No indication, no warning tone even though system is connected to mains power supply	No input voltage	Check building wiring socket outlet and input cable.
	Input switch has disconnected [for 6K(H)/ 10K(H)]	Set the Input switch to “ON”
LINE LED blinks	Phase and neutral conductor at input of UPS system are reversed	Rotate mains power socket by 180 °C or connect UPS system according to chapter 5 “onnection and operation” .
LINE LED blinks and BATTERY-LED lights up	Input power and/or frequency are out of tolerance	Check input power source and inform dealer if necessary
LINE and BYPASS LED light up even though the power supply is available	Inverter not switched on	Press On-Switch “1”
INVERTER LED lights up, and audible alarm sounding every 1 or 4 seconds	Mains power supply has failed	Switching to battery mode automatically. When audible alarm sounding every second, battery is almost empty.
INVERTER LED lights up, warning tone at intervals of every 1 or 4 seconds, mains power supply available [for 6K/ 10K]	Input switch disconnected	Set the Input switch to “ON” . If the problem persists, please inform your dealer.
FAULT LED lights, warning tone once a second	Overload	Remove loads of UPS output.
FAULT-LED lights up, permanent warning tone	UPS fault	Notify dealer!!
Emergency supply period shorter than nominal value	Batteries not fully charged / batteries defect	Charge the batteries for at least 1 - 2 hours and then check capacity. If the problem still persists, consult your dealer.
FAULT LED lights, BATTERY-LED blinks, warning tone once a second	Charger or Batteries damaged	Notify dealer!!
FAULT LED lights, Indicator3 and Indicator6 lights, permanent warning tone	BATSCR short [for 6K/ 10K]	Notify dealer!!

Please have the following information at hand before calling the After-Sales Service Department:

1. Model number, serial number
2. Date on which the problem occurred
3. Detailed description of the problem

7. Maintenance

7-1 Operation

The UPS system contains no user-serviceable parts. If the battery service life (3~5 years at 25 °C ambient temperature) has been exceeded, the batteries must be replaced. In this case please contact your dealer.

7-2 Storage

If the batteries are stored in temperate climatic zones, they should be charged every three months for 8-10 hours (see Chapter 5 "Connection and Operation"). You should shorten the charging intervals to two months at locations subject to high temperatures.

8. Technical data

8.1 Electrical specifications

INPUT

Model No.	1K	2K	3K	6K	10K	3P10K
Voltage	115~300VAC		176~276VAC			305~478VAC
Frequency	(46~54)Hz / (56~64)Hz					
Current(A)	7A	12A	16A	30A	47A	

OUTPUT

Model No.	1K	2K	3K	6K	10K	3P10K
Power rating	0.7kW	1.4kW	2.1kW	4.2kW	7kW	
Voltage	220/230/240 × (1 ± 2%)VAC			220/230/240 × (1 ± 1%)VAC		
Frequency	50/60 × (1 ± 0.2%)Hz (Battery mode)			50/60 ± 0.05Hz		
Wave form	Sinusoidal					

BATTERIES

Model No.	1KS	2KS	3KS	6KS	10KS	3P10KH
Voltage	3 × 12V 7.0Ah	8 × 12V 7.0Ah	20 × 12V 7.0Ah	20 × 12V 9.0Ah	External	

8.2 Operating Environment

Ambient Temperature	0°C to 40°C
Operating humidity	< 95%
Altitude	< 1000m
Storage temperature	0°C~40°C

8.3 Typical stored energy time (Typical values at 25°C in minutes:)

Model No.	100 % Load	50 % Load
1K	5	14
2K	9	21
3K	5	15
6K	8	23
10K	5	12
3P10K	5	12

8.4 Dimensions and weights

Model No.	Dimensions W × D × H (mm)	Net Weight(kg)
1KS	145 × 400 × 220	14
1KH	145 × 400 × 220	7
2KS	192 × 460 × 340	34.5
2KH	192 × 460 × 340	15
3KS	192 × 460 × 340	35.5
3KH	192 × 460 × 340	16
6KS	260 × 570 × 717	90
6KH	260 × 570 × 717	35
10KS	260 × 570 × 717	93
10KH	260 × 570 × 717	38
3P10KH	260 × 570 × 717	44

Only the units with CE markings are comply with the following standards:

1) For 1K / 2K / 3K

EN62040-1-1 (safety)

Conducted Emission: EN50091-2.....Class B

Radiated Emission: EN50091-2.....Class B

Harmonic Current: EN61000-3-2
 Voltage Fluctuations and Flicker: EN61000-3-3
 EMS: EN61000-4-2(ESD).....Level 4
 EN61000-4-3(RS)Level 3
 EN61000-4-4(EFT).....Level 4
 EN61000-4-5(lightning surge).....Level 4
 EN61000-2-2 (Immunity to low frequency signals)

For 6K / 10K / 3P10K

EN62040-1-1 (safety)
 Conducted Emission:EN50091-2 : Limits for UPS which have a rated output current exceeding 25A(25~100A)
 Radiated Emission: EN50091-2: Limits for UPS which have a rated output current exceeding 25A(25~100A)
 EMS: EN61000-4-2(ESD).....Level 4
 EN61000-4-3(RS).....Level 3
 EN61000-4-4(EFT).....Level 4
 EN61000-4-5(lightning surge).....Level 4
 EN61000-2-2 (Immunity to low frequency signals)

9. Communication port

9.1 RS232 Interface

The following is the pin assignment and description of DB-9 connector.

Pin #	Description	I/O
2	TXD	Output
3	RXD	Input
5	GND	Input

9.2 SNMP Interface(Optional)

Except for the communication protocol as mentioned above, this series UPS has SNMP card (an optional accessory) . Please contact your local distributor for details.

APPENDIX

APPENDIX I : Front panel LED display and Work Model parallelism diagram
1KVA, 2KVA and 3KVA:

No	Work Model	LED No										Alarm Beep	
		1#	2#	3#	4#	5#	6#	7#	8#	9#	10#		
1	Main Power	0%~35% Load Capacity						●		●	●		No
2		36%~55% Load Capacity					●	●		●	●		No
3		56%~75% Load Capacity				●	●	●		●	●		No
4		76%~95% Load Capacity			●	●	●	●		●	●		No
5		96%~105% Load Capacity	●	●	●	●	●			●	●		No
6	Battery Power	0%~25% Battery Capacity	●							●	●		Once/1s
7		26%~50% Battery Capacity	●	●						●	●		Once/4s
8		51%~75% Battery Capacity	●	●	●					●	●		Once/4s
9		76%~100% Battery Capacity	●	●	●	●				●	●		Once/4s
10		100% Battery Capacity	●	●	●	●	●			●	●		Once/4s
11	Bypass Model		↑	↑	↑	↑	●	●	●				Once/2min
12	Overload at main power, switch to bypass	●	●	●	●	●	●	●					Lasting Beep
13	Overload at main power, not switch to bypass	●	●	●	●	●			●	●			Twice/1s
14	Main power abnormality		↑	↑	↑	↑	●	↑	★	↑	↑		↑
15	Overload at battery power, warning	●	●	↑	↑	↑	↑			●	●		Twice/1s
16	Overload at battery power, cut off output	●	●										Lasting Beep
17	Overheat	●					●	↑	↑				Lasting Beep
18	Inverter abnormality	●				●		↑	↑				Lasting Beep
19	BUS voltage abnormality	●			●			↑	↑				Lasting Beep
20	Charger output voltage higher	●		●				↑	↑				Lasting Beep
21	Battery voltage abnormality	↑	↑	↑	↑	↑	●					★	↑
22	Main input L/N in reverse		↑	↑	↑	↑	●	↑	★	↑	↑		Once/2min
23	Charger or battery fault	●										★	Once/1s
24	Output short circuit	●	●			●			↑				Lasting Beep
25	Fan abnormality	●	●				●	↑	↑	↑			Once/1s

●: Lasting light, ★: Blink, ↑: LED or alarm rest with others

6KVA /10KVA / 3P10K :

No	Work Model	LED No										Alarm Beep				
		1#	2#	3#	4#	5#	6#	7#	8#	9#	10#					
1	Main Power	0%~35% Load Capacity								●		●	●		No	
2		36%~55% Load Capacity								●	●		●	●	No	
3		56%~75% Load Capacity					●	●	●		●	●		●	●	No
4		76%~95% Load Capacity				●	●	●	●		●	●		●	●	No
5		96%~105% Load Capacity		●	●	●	●	●	●		●	●		●	●	No
6	Battery Power	0%~20% Battery Capacity		●										●	●	Once/1s
7		21%~40% Battery Capacity		●	●									●	●	Once/4s
8		41%~60% Battery Capacity		●	●	●								●	●	Once/4s
9		61%~80% Battery Capacity		●	●	●	●							●	●	Once/4s
10		81~100% Battery Capacity		●	●	●	●	●						●	●	Once/4s
11	Bypass Model			↑	↑	↑	↑	●	●	●					Twice/2min	
12	Overload at main power, not switch to bypass	●	●	●	●	●	●	●					●	●	Twice/1s	
13	Overload at main power, switch to bypass	●	●	●	●	●	●	●		●	●				Twice/1s	
14	Main power abnormality		↑	↑	↑	↑	↑	●	↑	★	↑	↑			↑	
15	Overload at battery power, warning	●	●	↑	↑	↑	↑					↑	●	●	Twice/1s	
16	Overload at battery power, cut off output	●	●										↑		Lasting Beep	
17	Overheat	●								●	↑	↑			Lasting Beep	
18	Inverter abnormality	●					●				↑	↑			Lasting Beep	
19	Output short circuit	●	●				●				↑	↑			Lasting Beep	
20	BUS voltage abnormality	●				●					↑	↑			Lasting Beep	
21	Charger or Battery fault	●										↑	↑	↑	★	Once/1s
22	BATSCR short circuit	●		●						●	↑	↑				Lasting Beep
23	Fan abnormality	●	●							●	↑	↑	↑	↑		Once/1s
24	Inverter RLY short circuit	●					●			●	↑	↑				Lasting Beep
25	Interior communication abnormality	●			●	●					↑	↑				Lasting Beep
26	Parallel abnormality	●	●	●						●		↑				Lasting Beep

●: Lasting light, ★: Blink, ↑: LED or alarm rest with others

APPENDIX II : Parallel operation (6KVA and 10KVA)

1. Brief introduction of the redundancy

$N+X$ is currently the most reliable power supply structure. N represents the minimum UPS number that the total load needs; X represents the redundant UPS number, i.e. The fault UPS number that the system can handle simultaneously. The bigger the X is, the higher reliability of the power system is. For occasions where reliability is highly depended on, $N+X$ is the optimal mode.

As long as the UPS is equipped with parallel cables, up to 3 UPSs can be connected in parallel to realize output power sharing and power redundancy.

2. Parallel installation

1) Users need to opt a standard 25-pin communication cable, which should have 25 cores, correspondings stitches and shield, as the UPS parallel cable. The length of the parallel cable is appropriate to be less than 3m.

2) Strictly follow the stand-alone wiring requirement to perform the input wiring of each UPS.

3) Connect the output wires of each UPS to an output breaker panel, disconnect the jumper on JP1 and JP2 of the terminal block first, and connect each output breaker to a main output breaker and then to the loads.

The requirement of the output wiring is as follows:

- » When the distance between the UPS in parallel and the breaker panel is less than 20 meters, the difference between the wires of input & output is required to be less than 20%.
- » When the distance between the UPS in parallel and the breaker panel is greater than 20 meters, the difference between the wires of input & output is required to be less than 10%.

3. Operation and maintenance

1) To perform the general operation, follow the stand-alone operating requirement;

2) Startup: The units transfer to INV mode simultaneously as they start up sequentially in utility power mode;

Shutdown: the units shut down sequentially in INV mode. When the last one completes the shutdown action, each unit will shut down the inverter simultaneously and transfer to bypass mode.

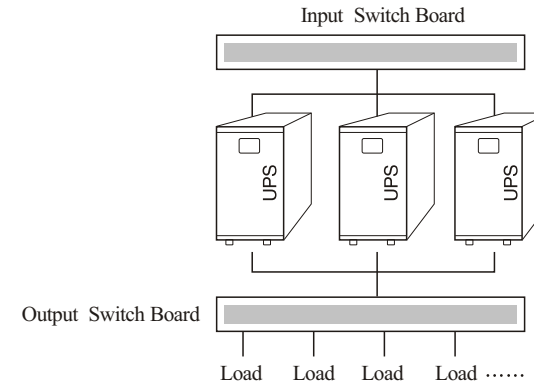

Parallel Installation Diagram

